

4527A WALK AROUND DEMO CHART

- 51 ft working height
- 27 ft maximum outreach
- Platform jib + boom extension
- Automatic leveling
- Hydraulic outriggers

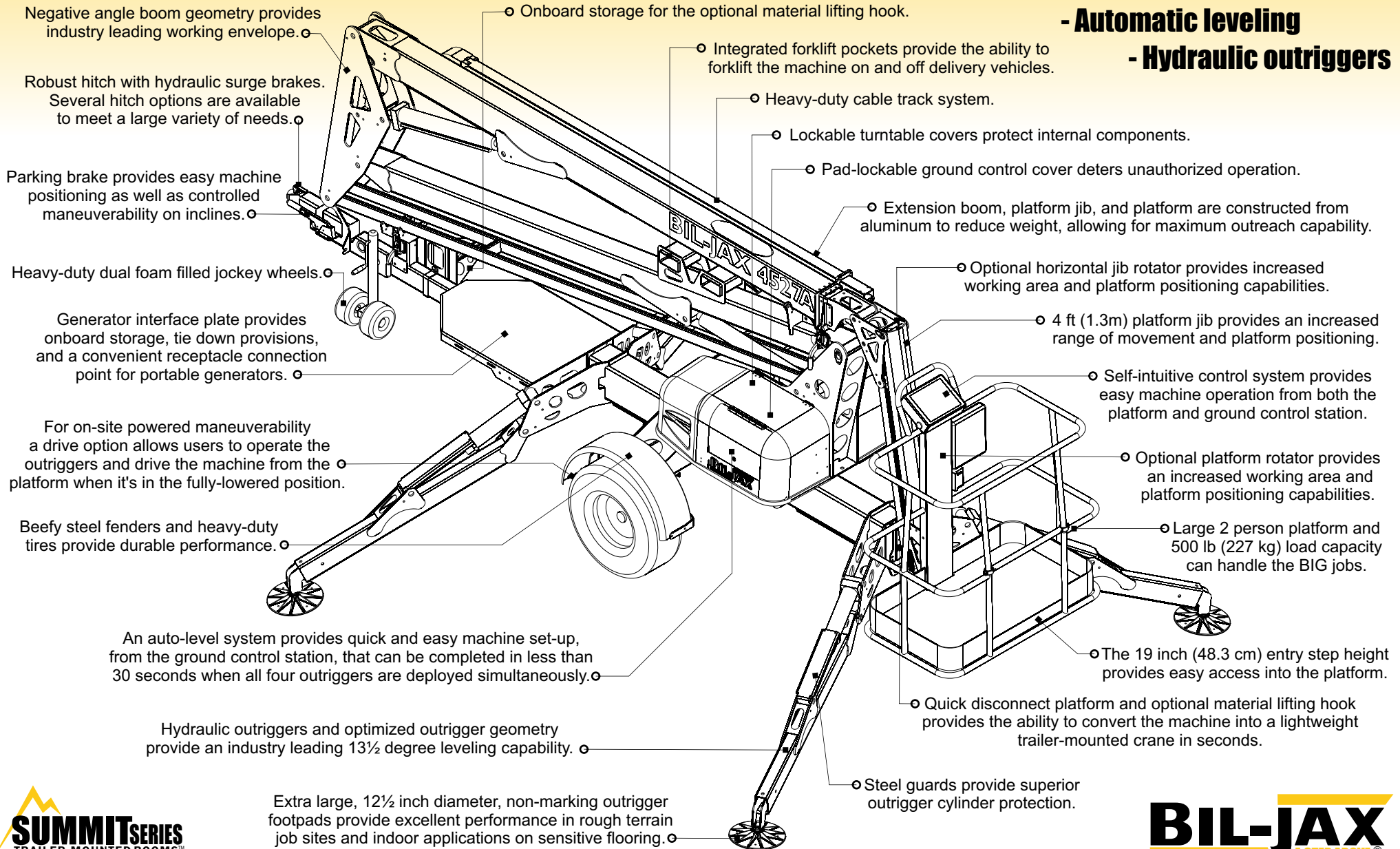

SUMMIT SERIES
TRAILER-MOUNTED BOOMS™

© Bil-Jax, Inc. 2006
Part No. 0205-0054

For a complete listing of specifications, options and accessories; please reference the Summit Series catalog.

BIL-JAX
A STEP ABOVE®

125 Taylor Parkway, Archbold, OH 43502
800-537-0540, www.biljax.com

IT'S ALL WITHIN YOUR REACH...

OUTREACH

(FROM CENTERLINE OF TURNTABLE BEARING)

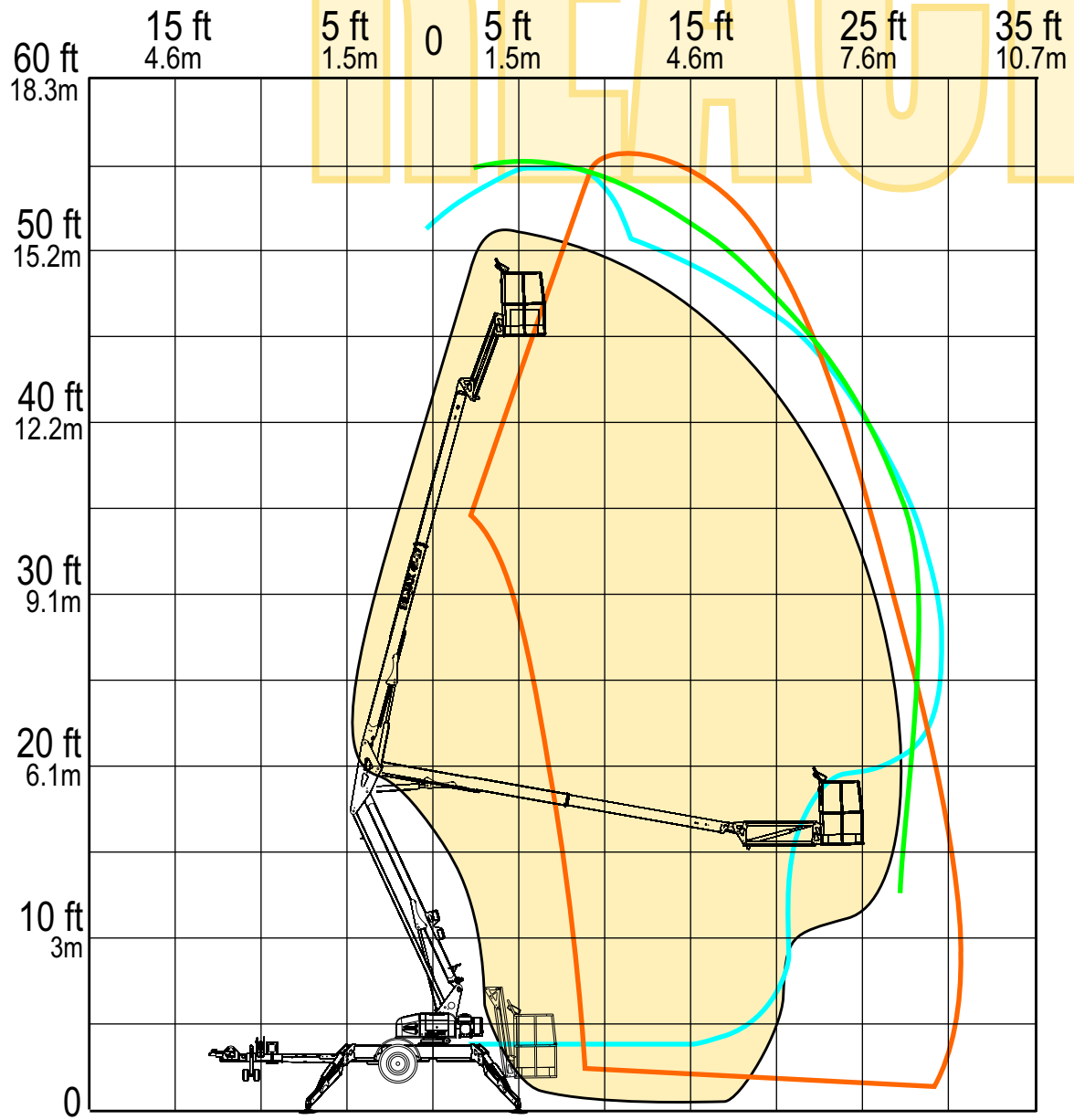

50 ft models from:

4527A vs.

COMPETITOR G
COMPETITOR J

COMPETITOR N

MORE

SUMMITSERIES
TRAILER-MOUNTED BOOMS™

BIL-JAX TRAILER-MOUNTED
BOOMS
A STEP ABOVE®

Effective: 2/1/06